

CAD FILE:

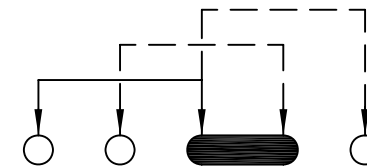

SCHEMATIC (SHORTING)

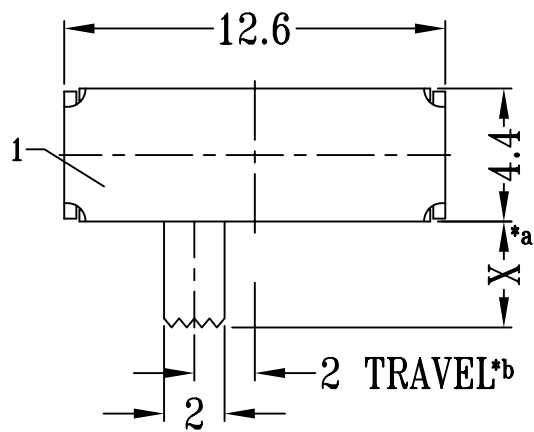
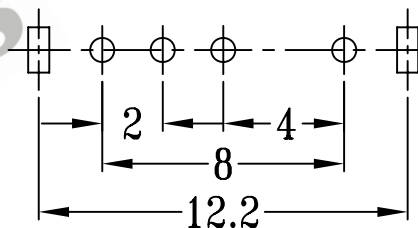
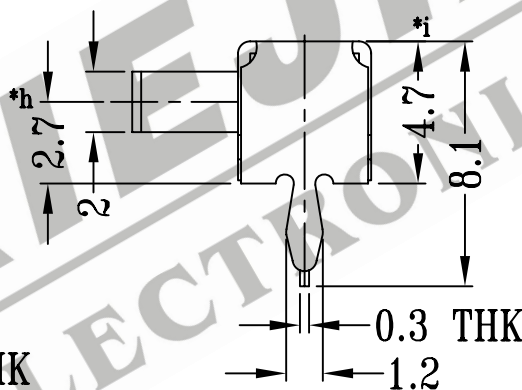
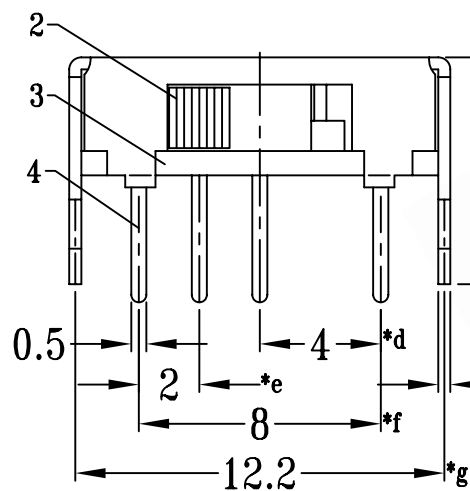

P.C.B LAYOUT

注:带"*"表示关键尺寸(9个)

| NO. | PARTS | MATERIALS | Q'TY | FINISH | TOLERANCE UNLESS SPECIFIED | SHENZHEN XIEJIA ELECTRONICS CO.,LTD. | | | | |
|-----|--------------|-----------------|------|--------------------------|---|--------------------------------------|----------------------------|--------------------------|----------|-----------------|
| 8 | | | | | | TITLE : HORIZONTAL SLIDE SWITCH | | | | |
| 7 | | | | | | | | | | MODEL: SK-13D11 |
| 6 | SPRING PLATE | STAINLESS STEEL | 1 | NATURAL | WITHIN: 1.5±0.1mm | ISSUE | DATE | DESCRIPTIONS OF REVISION | | |
| 5 | CONTACT CLIP | PBS | 1 | Ag CLAD | OVER: 1.5±0.2mm | | | | | |
| 4 | TERMINAL | BRASS STRIP | 4 | Ag PLATED OVER Ni PLATED | | UNIT : mm | DRWG NO.: XJ-DR-SK13D11-00 | | | |
| 3 | BASE | PHENOLIC RESIN | 1 | NATURAL | | SCALE: 4:1 | DWN. | ZHOUYU | 2005-7-9 | |
| 2 | KNOB | POM | 1 | BLACK | | | CHK'D | FANGYING | 2005-7-9 | |
| 1 | FRAME | STEEL STRIP | 1 | Ni PLATED | | APPD. | KANGXINAN | 2005-7-9 | | |
| | | | | | ALL MATERIALS MUST BE COMPLIANT TO ROHS | | | | | |